

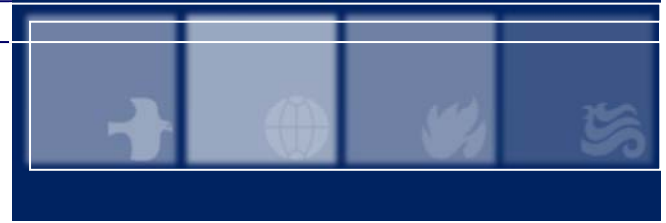

SENER

Ingeniería y Sistemas S.A.

ThalesAlenia
A Thales / Finmeccanica Company
Space



SEOSAT/Ingenio Industrial Day. Primary Payload.

SEOSAT/Ingenio Industrial Day Primary Payload

17 November 2008

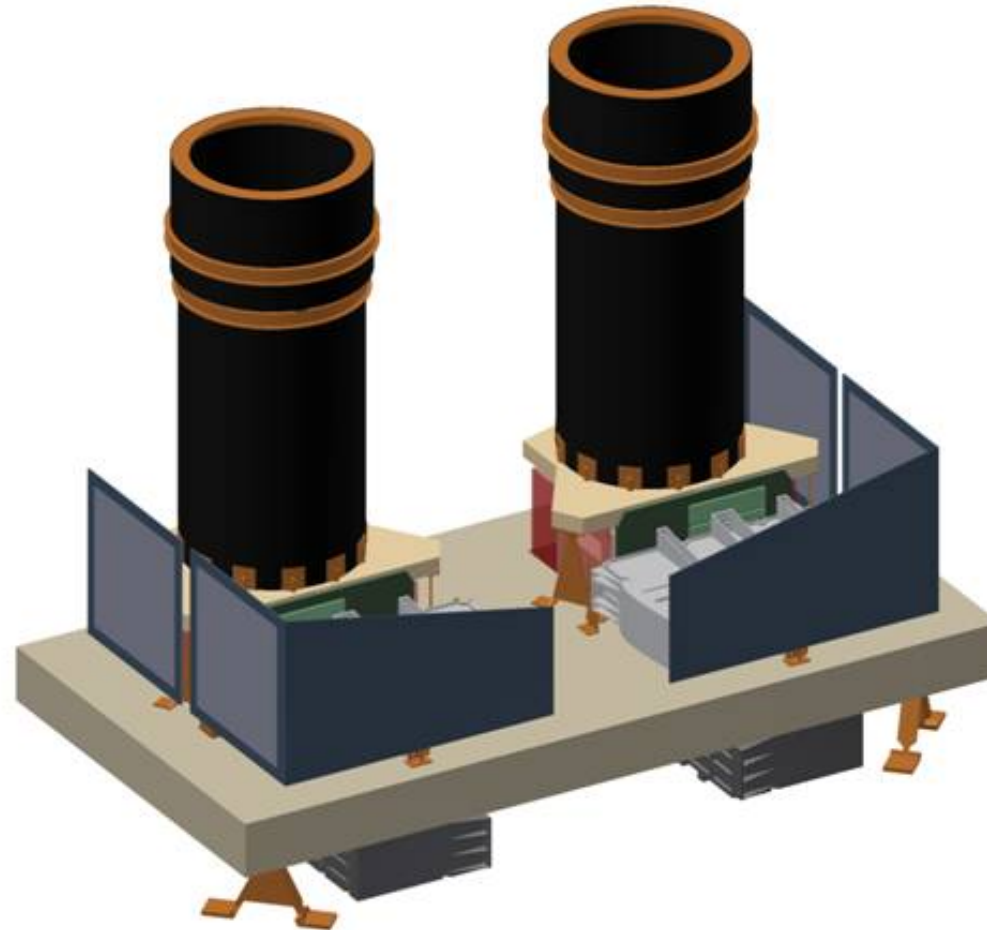



SENER

Ingeniería y Sistemas S.A.

ThalesAlenia
A Thales / Finmeccanica Company
Space



SEOSAT/Ingenio Industrial Day. Primary Payload.

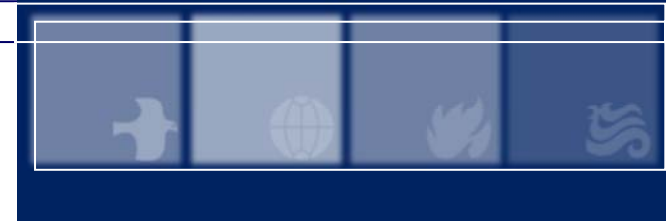

Contents:

- 1. Primary Payload Description**
- 2. Primary Payload Industrial Procurement Plan**
- 3. Primary Payload ITT Schedule**

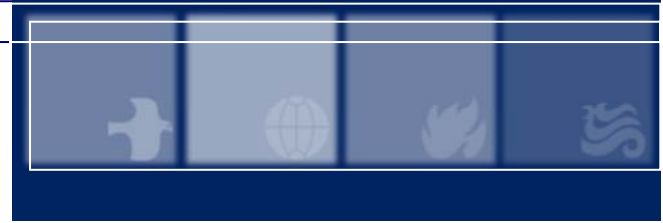

SEOSAT/Ingenio Industrial Day. Primary Payload.

1. Primary Payload (PP) Description. Overall Configuration

- PP (Instrument) consists of 2 cameras for 60km (30km each): 2xKorsh
- Each camera (GSD: 2.5m PAN & 10m MS, 2.5° FoV) consist of:
 - Image Formation S/S: Optical Telescope with Focal Plane
 - Optical telescope (opto-mechanics): structural and optical part
 - Focal Plane (FP): high stability H/W including the Equipped Detectors (ED)
 - Equipped Detectors (ED): each include detector, support, proximity electronics, filter,...
 - Proximity Electronics (PE): extracts the detector signal (pre-amplification)
 - Detection Unit (DU): Focal Plane (FP) + Video Unit (VU)
 - Video Unit (VU): Analogue processing of pre-amplified signal, and digitalization.
 - Instrument Service Unit (ISU)
 - Video Power Supply (VPS): high stable power supply for VU
 - Instrument Control Module (ICU): performs the control and command
 - High stability panel and isostatic mountings
 - Thermal HW
- **Channels:**
 - Panchromatic (B/W)
 - Multi-spectral (RGB+NIR), four bands



SEOSAT/Ingenio Industrial Day. Primary Payload.

1. Primary Payload (PP) Description. Overall Configuration.

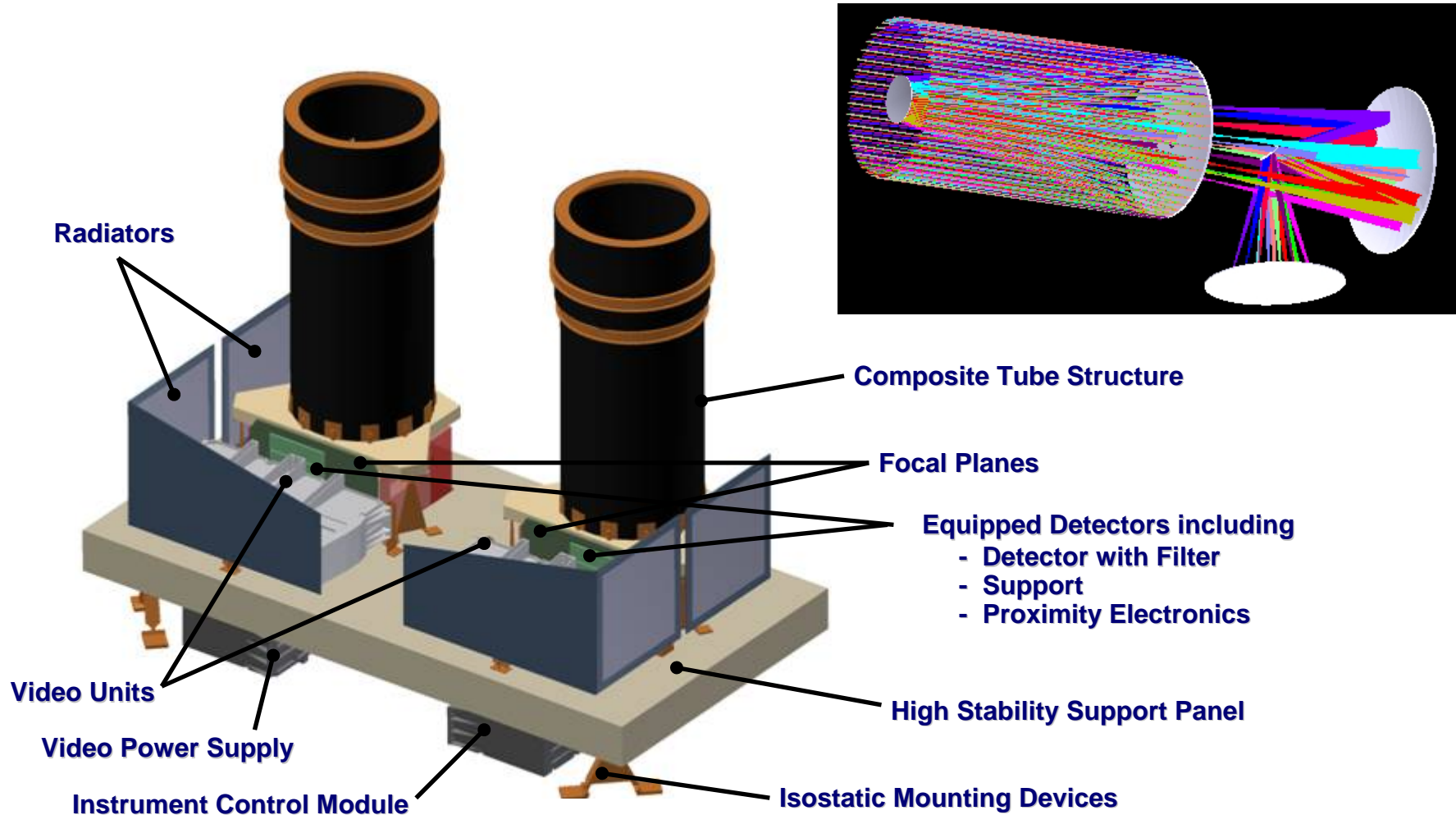



SENER

Ingeniería y Sistemas S.A.

ThalesAlenia
A Thales / Finmeccanica Company
Space

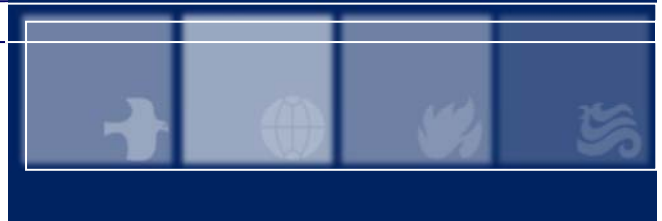

SEOSAT/Ingenio Industrial Day. Primary Payload.

1. Primary Payload (PP) Description. Overall Configuration

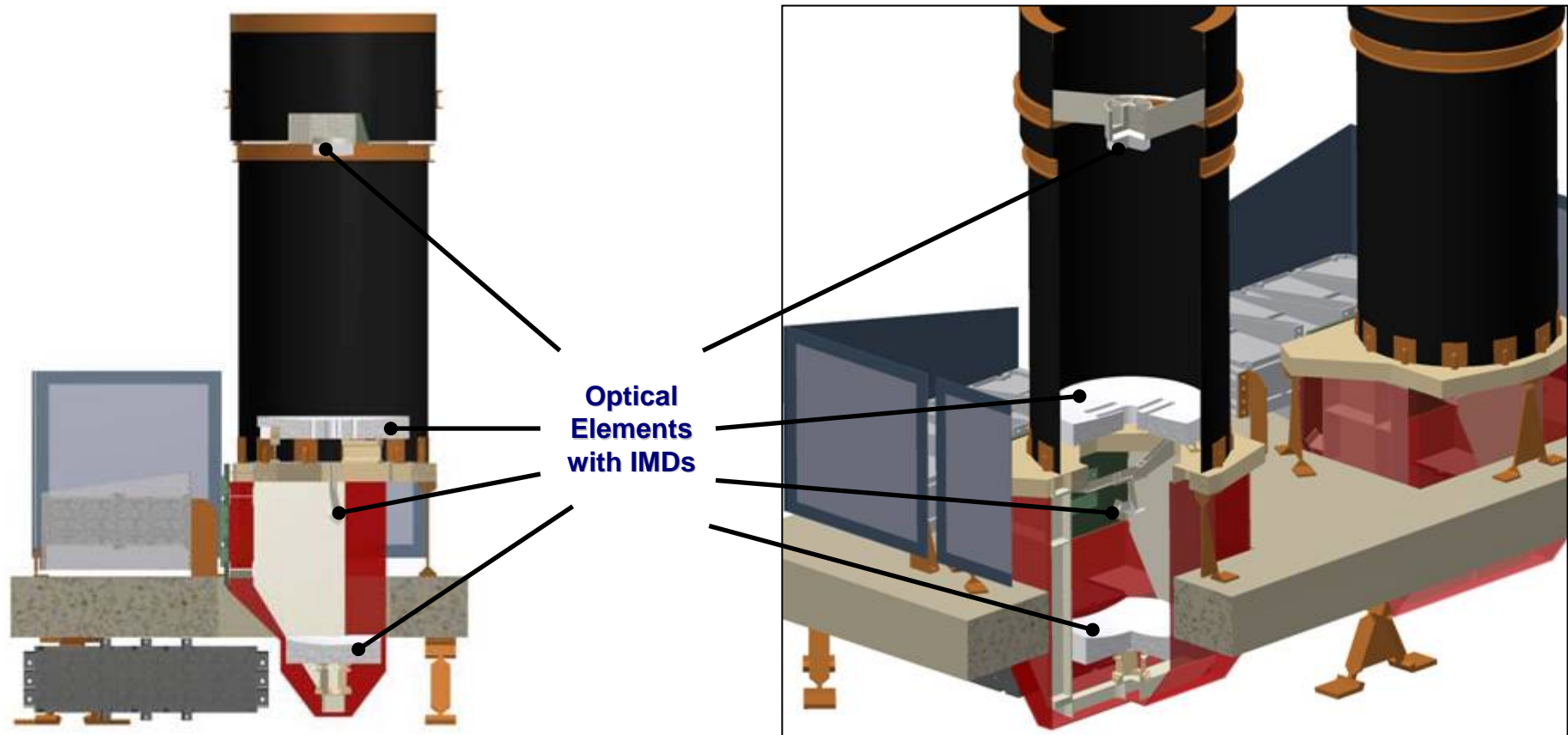



SEOSAT/Ingenio Industrial Day. Primary Payload.

1. Primary Payload (PP) Description. Architecture

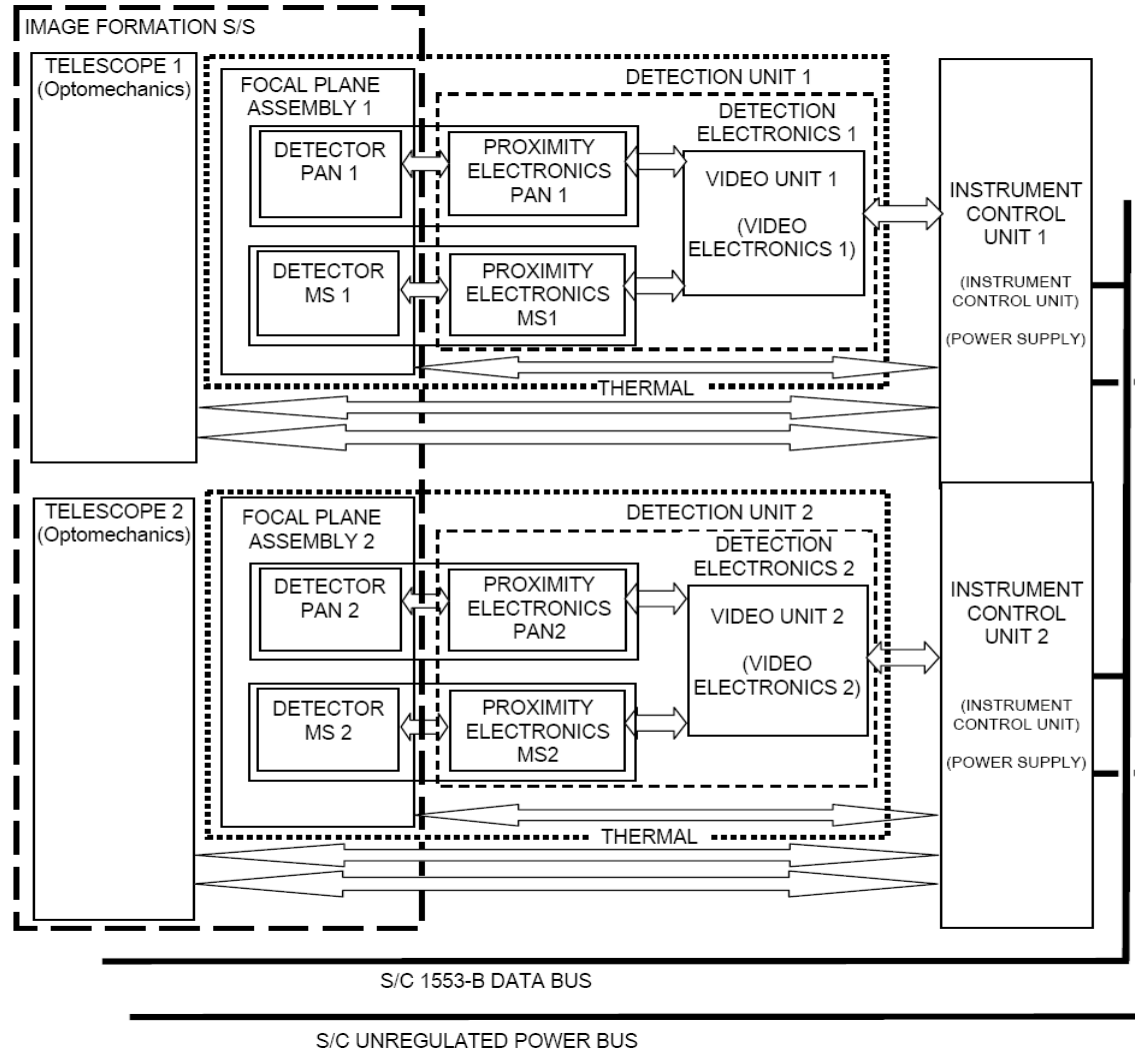

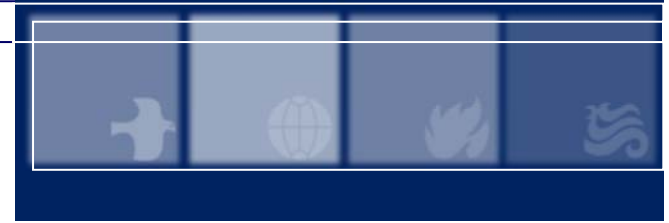

SEOSAT/Ingenio Industrial Day. Primary Payload.

1. Primary Payload (PP) Description. Characteristics

PRIMARY PAYLOAD INSTRUMENT: 2 x Korsch					
PAN DETECTOR - E2V CCD98-50			MS DETECTOR - E2V AT71554		
Swath	[km]	2 x (15 + 15)	Swath	[km]	2 x (15 + 15)
GSD	[m]	2,5	GSD	[m]	10
Nº Detectors	[]	2 x (1 + 1)	Nº Detectors	[]	2x (1 + 1)
Nº pixels	[]	2 x (20x6000 + 20x6000)	Nº pixels	[]	2 x (4x1500 + 4x1500)
Pixel size	[µm]	13	Pixel size	[µm]	52
FoV	[°]	2 x 2,539	FoV	[°]	2 x 2,539
Focal	[mm]	3520	Focal	[mm]	3520
Pupil Diameter	[mm]	220	Pupil Diameter	[mm]	220
f/#	[]	16	f/#	[]	16



SEOSAT/Ingenio Industrial Day. Primary Payload.

1. Primary Payload (PP) Description. Detectors

– Panchromatic Detector: PAN E2V CCD98-50 CCD technology

- TDI: up to 20 TDI stages in any of five preset TDI lengths (7, 10, 13, 16, 20).
- 20 TDI (Time Delay Integration) stages x 6000 pixels array.
- 13 μ m (□) pixel size
- Filter

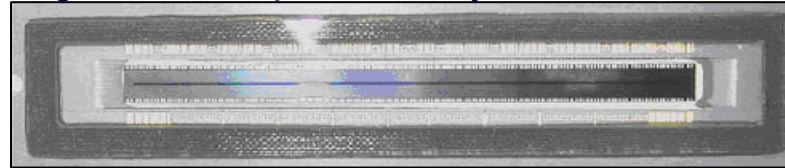

– Multi-spectral: MS E2V AT71554 linear (4) detector CCD technology

- Four colours RGB+NIR.
- Multi-strip filters
- 4 lines of 1500 pixels array.
- 52 μ m (□) pixel size.

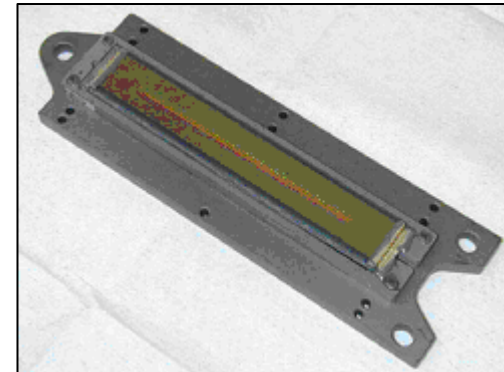

– Equipped Detectors includes

- Detector
- Support (SiC TBC)
- Filter
- Proximity electronics with its shielding case
- Frontal window structure (baffling)
- Thermal pads.

– Equipped Detectors are mounted on Focal Plane

SEOSAT/Ingenio Industrial Day. Primary Payload.

1. Primary Payload (PP) Description. Electronics

- Functional architecture
- 2 Cameras: Master clock (N&R) implemented in Instrument Control Module (ICU) and distributed to each Detection Unit
- Video Power Supplies (VPS): functional part of the Video Unit but implemented in a separate stack.
- ICU (N&R) in different physical box than VPS

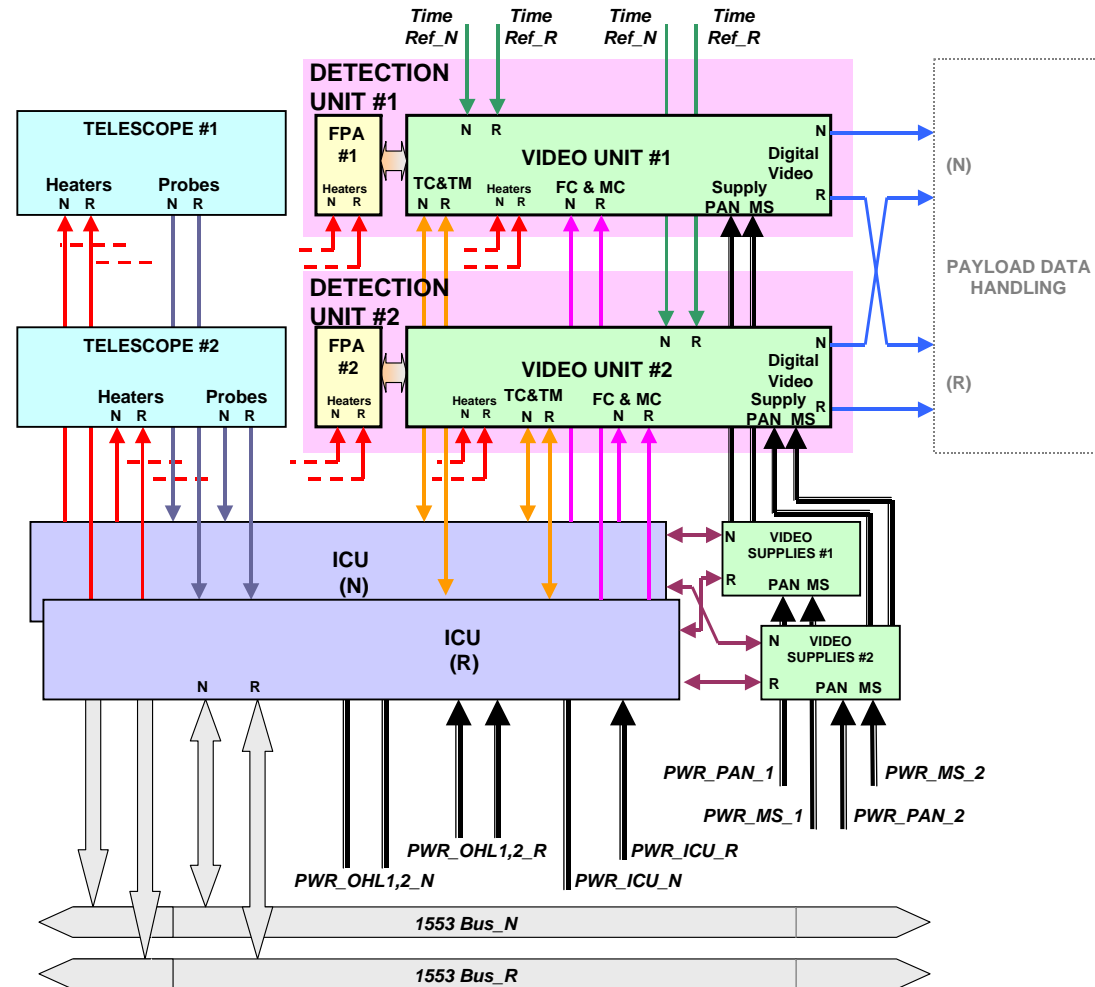

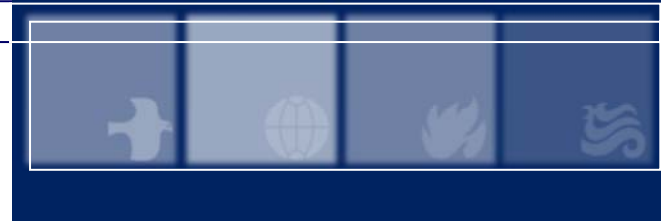

SEOSAT/Ingenio Industrial Day. Primary Payload.

1. Primary Payload (PP) Description. Integration/Verification Levels

- **First Integration/Verification Level:**
 - Equipped Detectors (in TAS-E & in SENER)
 - Detectors
 - Filter
 - Support structure
 - Proximity Electronics
 - Window
- **Second Integration/Verification Level:**
 - Focal Plane (FP) (in SENER)
 - Equipped detectors
 - FP Structure
 - FP Thermal Control
 - Video Unit (VU) (in TAS-E)
 - Video Electronics
 - Video Unit Structure
 - Instrument Service Unit (ISU = ICU + VPS) (in TAS-E)
- **Third Integration/Verification Level:**
 - Telescope (in INTA with SENER support)
 - Optics
 - Structure, Supports & Baffles
 - Thermal Control
 - Detection Unit (DU) (in TAS-E)
 - Focal Plane
 - Video Unit
- **Fourth Integration/Verification Level:**
 - Instrument (in INTA with SENER support)
 - Telescope
 - Detection Unit (DU)
 - Instrument Service Unit (ICU, Power Supply) (ISU)

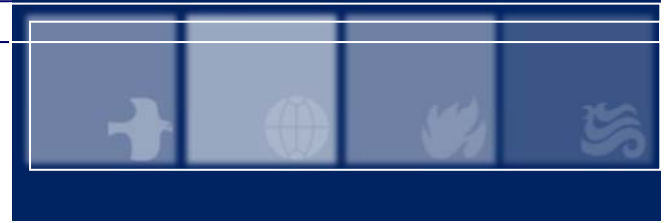

SEOSAT/Ingenio Industrial Day. Primary Payload.

2. Primary Payload (PP) Industrial Procurement Plan (IPP). Approach

– Followed Criteria:

- Provide maximum transparency within procurement process
- Ensure fairness or competition and impartiality in the evaluation
- Ensure respect to the general principle of cost efficiency
- Maximum involvement of Spanish existing industrial competences
- Make use of companies having well established technologies
- Minimisation of developments
- Minimisation of risks

– All that maintaining:

- Achievement of performances
- Fulfilment of schedule
- Optimization of cost

– PP Core Team led by SENER has been defined, involving:

- Schedule critical activities
- Performance achievement critical activities

– Sole source suppliers are identified and formal commitment is available

– PP IPP approved by customers and by Industrial Policy Authority: CDTI



SEOSAT/Ingenio Industrial Day. Primary Payload.

2. Primary Payload (PP) Industrial Procurement Plan (IPP). Configuration

– PP Core Team:

- SENER: SEOSAT/Ingenio Primary Payload (PP) responsible
- THALES-ALENIA-SPACE-ESPAÑA (TAS-E) : PP electronics responsible
- INTA: Instrument Assembly, Integration & Verification services responsible

– Procurement Methods:

- ITT SP: Invitation To Tender restricted to Spanish companies
- ITT NSP: Invitation To Tender Non restricted to Spanish companies
- RFQ: Request For Quotation on a single identified company
- PO: Purchase Order out of ESA Best Practices (standard company procedures)

– ITTs (most of them):

- Prepared by the Core Team company that have the ITT item under its responsibility
- Processed following ESA Best Practices and issued with Agency's procurement tool for External Entities (EMITS.EE), & published in ECE's web-site
 - for world-wide procurements ITTs: published in ECE's web site & sent via e-mail to already identified companies, or companies who have requested so.
- ITT content:
 - Cover Letter, SOW, SPEC, Draft Contract, Condition of Tender
- Proposals answering to ITT will be evaluated through a Tender Evaluation Board



SEOSAT/Ingenio Industrial Day. Primary Payload.

2. Primary Payload (PP) Industrial Procurement Plan. Summary Table

Item	Element	Procurement Method					
		CT SEN	CT REST	RFO	ITT SP	ITT NSP	PO
1.	Primary Payload Instrument	X					
1.1	Telescope	X					
1.1.1	Structure	X					
1.1.1.1	High Stability Support Panel					X	
1.1.1.2	Composite Pieces					X	
1.1.2	Optics & IMDs					X	
1.1.3	MGSE	X					
1.2	Focal Plane	X					
1.2.1	Equipped Detectors	X					
1.2.1.1	Filters					X	
1.2.2	FP Structure	X					
1.2.2.1	FP Structure Pieces					X	
1.3	Instrument Electronics		X				
1.3.1	Detection Electronics		X				
1.3.1.1	Detectors			X			
1.3.1.2	Proximity Electronics		X				
1.3.1.3	Video Unit		X				
1.3.1.3.1	Video Boards		X				
1.3.2	Instrument Service Unit		X				
1.3.2.1	Video Power Supply Boards		X				
1.3.2.2	Instrument Control Module				X		
1.3.3	EGSE		X				
1.3.3.1	Test Driver & Platf.Simulator				X		
1.3.4	Support Sys, AIT, EGSE		X				
1.4	Thermal Control H/W						X
1.5	HI-Rel EEE H/W						X
1.6	Instrument AIT		X				

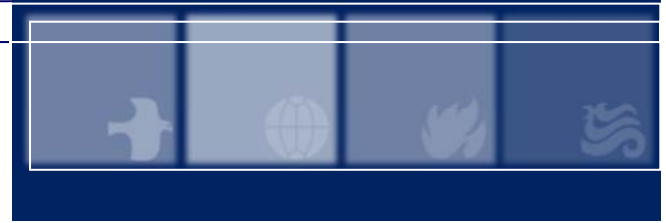

SEOSAT/Ingenio Industrial Day. Primary Payload.

2. Primary Payload (PP) Industrial Procurement Plan. Classification

- **ITTs under PP responsibility restricted to Spanish Companies:**
 - Instrument Control Module (ICU): under TAS-E responsibility
 - EGSE Test Driver & EGSE Platform Simulator: under TAS-E responsibility
- **ITTs under PP responsibility non restricted to Spanish Companies:**
 - High Stability Support Panel: under SENER responsibility
 - Composite tubular pieces: under SENER responsibility
 - Optical elements and their IMDs: under SENER responsibility
 - Filters: under SENER responsibility
 - FP Structural Pieces (SiC): under SENER responsibility
- **RFQs under PP responsibility**
 - Detectors: under TAS-E responsibility
- **POs under PP responsibility**
 - Instrument Thermal Control H/W: under SENER responsibility
 - Hi-Rel EEE H/W procurement: under SENER responsibility
- **Details follows, but may change according with design consolidation**



SENER

Ingeniería y Sistemas S.A.

ThalesAlenia
A Thales / Finmeccanica Company
Space

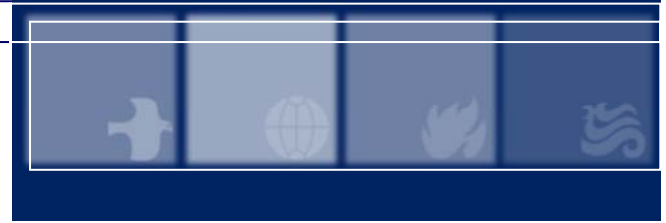

SEOSAT/Ingenio Industrial Day. Primary Payload.

2. Primary Payload (PP) Industrial Procurement Plan. Details

– Instrument Control Module (ICU): ITT SP (TAS-E responsibility)

- Detailed design, manufacturing, integration and verification.
- ICU is composed of N& R boards for each camera, and it consist of:
 - Interfaces with data link bus 1553.
 - Acquisitions of platinum probes (thermal sensors) for thermal control.
 - Housing parameters monitoring acquisition (voltages, temperatures, status).
 - Power supply of the thermal control heaters of the telescope.
 - TM/TC exchanged with the Video Unit.
 - TM/TC exchanged with Video Supply Unit.
 - Generation and distribution of Frame Clock and Master Clock signals for Video Units.

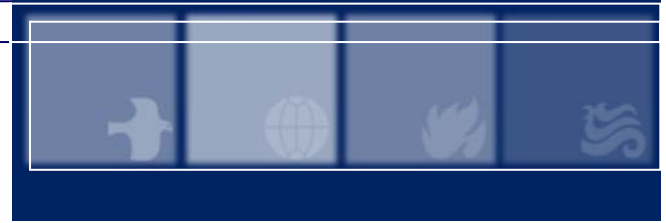

SEOSAT/Ingenio Industrial Day. Primary Payload.

2. Primary Payload (PP) Industrial Procurement Plan. Details (cont'd)

– EGSE Test Driver & Platform Simulator: ITT SP (TAS-E responsibility)

- Detailed design, assembly, integration and verification of both.
- Test Driver based on a Central Check Out system
 - Provides necessary tools
 - » to monitor and display the health and safety of instrument
 - » to drive the different EGSE modules
 - Based on a PC platform.
- Platform simulator:
 - Provides the following functions:
 - » Power function for the instrument equipments
 - » Control / command of the instrument, through the 1553 link
 - » Thermal regulation of the instrument
 - » Detection unit configuration (adjustment of the electronic parameters according to the AIT tests results)
 - » Clock generation
 - H/W is mounted in racks.

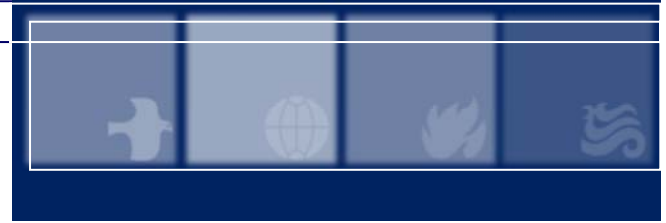

SEOSAT/Ingenio Industrial Day. Primary Payload.

2. Primary Payload (PP) Industrial Procurement Plan. Details (cont'd)

– High Stability Support Panel: ITT NSP (SENER responsibility)

- Manufacturing of High Stability Composite sandwich structure:
- Inserts and fittings to interface with IMD's to S/C and IMD's to Telescopes
- Includes:
 - Quasi-isotropic CFRP skins resin with AA core
 - » High modulus fibre with low moisture absorption resin
 - Metallic fittings/inserts to attach IMD's interfacing S/C
 - Metallic fittings/inserts to attach IMD's interfacing telescopes

– Composite tubular pieces: ITT NSP (SENER responsibility)

- Manufacturing of Composite tube structure
- It supports M2 to optical bench with high stability
- Includes:
 - CFRP Tube (high modulus fibre with low moisture absorption resin)
 - Metallic fittings to attach it to optical bench (high precision bonding)
 - Metallic fitting to support the M2 spider structure (high precision bonding)

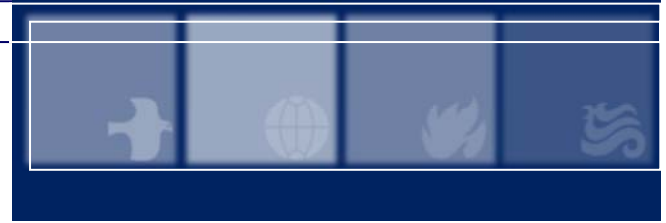

SEOSAT/Ingenio Industrial Day. Primary Payload.

2. Primary Payload (PP) Industrial Procurement Plan. Details (cont'd)

– Optical elements and their IMDs: ITT NSP (SENER responsibility)

- Detailed design and manufacturing of optical elements:
- Detailed design and manufacturing of optical elements IMD's
- Complete qualification (AIV) of each mirror with its IMD's
- Global functional verification on a lab test stand
- Includes: M1, M2, M3, MR

– Filters: ITT NSP (SENER responsibility)

- Detailed design, manufacturing and verification
- Includes:
 - Micro-strip filters for MS Detector
 - Filter for PAN Detector

– FP Structural Pieces: ITT NSP (SENER responsibility)

- Manufacturing of FP pieces (SiC)
- Includes
 - Structural pieces of Focal Plane

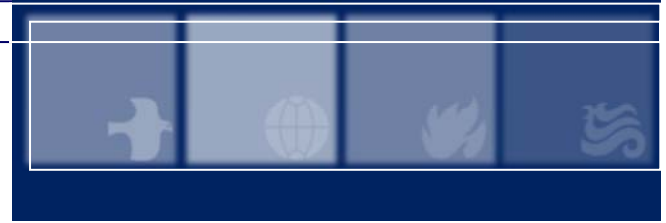

SEOSAT/Ingenio Industrial Day. Primary Payload.

2. Primary Payload (PP) Industrial Procurement Plan. Details (cont'd)

– Detectors: RFQ (TAS-E responsibility)

- Manufacturing and verification of detectors
- Includes:
 - PAN TDI Detector CCD98-50 CCD technology
 - MS AT71554 linear (4) detector CCD technology

– Instrument Thermal Control H/W: PO (SENER responsibility)

- Detailed design, manufacturing and integration of thermal control H/W
- Includes:
 - Individual Telescope thermal control H/W
 - Global Instrument thermal control H/W

– Hi-Rel EEE H/W procurement: PO (SENER responsibility)

- Hi-Reliability EEE procurement
- Includes
 - Thermal sensors
 - Thermostats
 - Heating elements
 - ...



SEOSAT/Ingenio Industrial Day. Primary Payload.

3. Primary Payload (PP) ITTs Schedule

- **Instrument Control Module (ICU): ITT SP (TAS-E responsibility)**
 - First quarter 2009
- **EGSE Test Driver & Platform Simulator: ITT SP (TAS-E responsibility)**
 - Second quarter 2009
- **High Stability Support Panel: ITT NSP (SENER responsibility)**
 - First quarter 2009
- **Composite tubular pieces: ITT NSP (SENER responsibility)**
 - First quarter 2009
- **Optical elements and their IMDs: ITT NSP (SENER responsibility)**
 - First quarter 2009
- **Filters: ITT NSP (SENER responsibility)**
 - Second quarter 2009
- **FP Structural Pieces (SiC): ITT NSP (SENER responsibility)**
 - Second quarter 2009
- **Detectors: RFQ (TAS-E responsibility)**
 - First quarter 2009
- **Instrument Thermal Control H/W: PO (SENER responsibility)**
 - Second quarter 2009
- **Hi-Rel EEE H/W procurement: PO (SENER responsibility)**
 - Third quarter 2009